

# ONE DISC CLUTCH for KART RACING ENGINES

**SMC** Roller Levers



**RED**

PATENTS  
6,279,711  
6,536,574  
Additional Patents Pending

## SPROCKET/DRUM ASSEMBLY

## CLUTCH ASSEMBLY

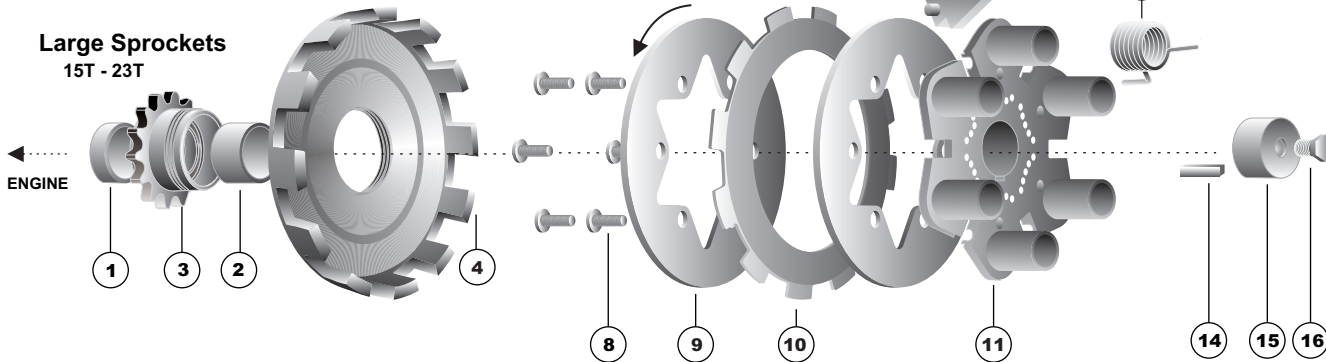

## PARTS

Ref. No.	Part No.	Price Each	Description (Number Required)
	<b>4201</b>	<b>330.00</b>	<b>VORTEX RED, One Disc Clutch</b>
1	4212	4.00	Chamfered Spacer (0.300 length)
2	4213	4.00	Spacer (0.575 length)
3	xxxx		SMC Sprocket (See Sprocket Chart)
4	4231	29.95	Drum, 12-Slots, One Disc, Left Hand
Threads			
8	4006	0.25	Button Head Cap Screw (6)
9	4003	16.00	Drive Plate (2)
10	4250	24.75	Clutch Disc, Twelve Tabs (1)
11	4241	130.00	Drive Hub, One Disc
12	4120	20.00	SMC Roller Lever (6)
13	4004	3.00	VORTEX Spring, Silver (6) (See Spring Chart)

## SMC RED SPROCKET CHART - #35 CHAIN

		Part No.	Price Each	Description
PTO Assembly	Small Sprockets	4659*	22.50	9T Sprocket Assembly
		4660*	22.50	10T Sprocket Assembly
		4661	22.50	11T Sprocket Assembly
		4662	22.50	12T Sprocket Assembly
		4663*	22.50	13T Sprocket Assembly
		4683	22.50	13T Sprocket Assembly
	Large Sprockets	4664*	22.50	14T Sprocket Assembly
		4684	22.50	14T Sprocket Assembly
		4665*	22.50	15T Sprocket Assembly
		4685	22.50	15T Sprocket Assembly
		4666*	22.50	16T Sprocket Assembly
		4686	22.50	16T Sprocket Assembly
		4667	22.50	17T Sprocket Assembly
		4668	22.50	18T Sprocket Assembly
4669	22.50	19T Sprocket Assembly		
4670	24.75	20T Sprocket Assembly		
4671	24.75	21T Sprocket Assembly		

### NOTES:

- Sprockets include Ball Bearing and Retaining Rings
- \* Right Hand Threads

## OPTIONAL PARTS

Ref. No.	Part No.	Price Each	Description (Number Required)
<b>9T &amp; 10T #35 Chain Sprockets:</b>			
1	4206	4.00	Chamfered Spacer (1.125 length)
4	4235*	29.95	Drum, 12-Slots, One Disc, R.H.
16	4205	0.75	Socket Head Cap Screw
<b>11T #35 Chain Sprockets:</b>			
2	4210	4.00	Spacer (0.813 O.D. x 0.575 length)
<b>12T #35 Chain Sprockets:</b>			
2	4204	4.00	Spacer (0.900 O.D. x 0.575 length)
	4221	55.00	<b>Rebuild Kit, One Disc Clutches</b> (two drive)

## TOOLS

Part No.	Price Each	Description (Number Required)
4218	20.00	SMC Sprocket Wrench
4018	15.00	VORTEX Spring Wrench

VORTEX Spring Chart	Silver	Black	Gold
B&S FLAT HEAD - STOCK	X	X	
B&S OVH - ANIMAL	X	X	
HONDA / CLONE	X	X	
MODIFIED		X	X
OPENS			X

# ONE DISC CLUTCH for KART RACING ENGINES

**SMC Roller Levers**



PATENTS  
6,279,711  
6,536,574  
Additional Patents Pending

## SPROCKET/DRUM ASSEMBLY

## CLUTCH ASSEMBLY

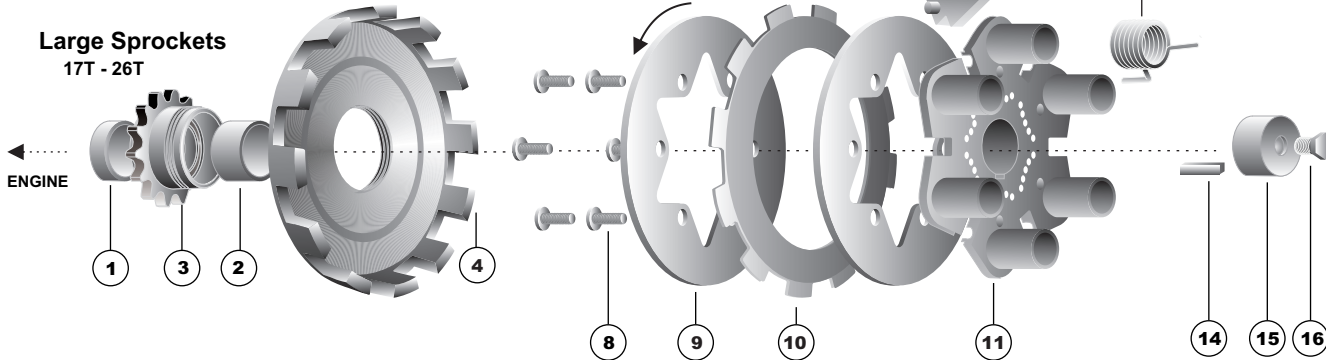

## PARTS

Ref. No.	Part No.	Price Each	Description (Number Required)
	<b>4201</b>	<b>330.00</b>	<b>VORTEX RED, One Disc Clutch</b>
1	4212	4.00	Chamfered Spacer (0.300 length)
2	4213	4.00	Spacer (0.575 length)
3	xxxx		SMC Sprocket (See Sprocket Chart)
4	4231	29.95	Drum, 12-Slots, One Disc, Left Hand
Threads			
8	4006	0.25	Button Head Cap Screw (6)
9	4003	16.00	Drive Plate (2)
10	4250	24.75	Clutch Disc, Twelve Tabs (1)
11	4241	135.00	Drive Hub, One Disc
12	4120	20.00	SMC Roller Lever (6)
13	4004	3.00	VORTEX Spring, Silver (6) (See Spring Chart)

## SMC RED SPROCKET CHART - #219 CHAIN

	Part No.	Price Each	Description
PTO Assembly	Small Sprockets	4761*	22.50 11T Sprocket Assembly
		4762*	22.50 12T Sprocket Assembly
		4763	22.50 13T Sprocket Assembly
		4764	22.50 14T Sprocket Assembly
		4765	22.50 15T Sprocket Assembly
		4766	22.50 16T Sprocket Assembly
		4767	22.50 17T Sprocket Assembly
PTO Assembly	Large Sprockets	4768	22.50 18T Sprocket Assembly
		4769	22.50 19T Sprocket Assembly
		4770	22.50 20T Sprocket Assembly
		4771	22.50 21T Sprocket Assembly
		4772	22.50 22T Sprocket Assembly
		4773	22.50 23T Sprocket Assembly
		4774	24.75 24T Sprocket Assembly

### NOTES:

- Sprockets include Ball Bearing and Retaining Rings
- \* Right Hand Threads

## OPTIONAL PARTS

Ref. No.	Part No.	Price Each	Description (Number Required)
<b>11T &amp; 12T #219 Chain Sprockets:</b>			
1	4206	4.00	Chamfered Spacer (1.125 length)
4	4235*	29.95	Drum, 12-Slots, One Disc, R.H.
16	4205	0.75	Socket Head Cap Screw
<b>13T &amp; 14T #219 Chain Sprockets:</b>			
2	4210	4.00	Spacer (0.813 O.D. x 0.575 length)
<b>15T #219 Chain Sprockets:</b>			
2	4204	4.00	Spacer (0.900 O.D. x 0.575 length)
	4221	55.00	<b>Rebuild Kit, One Disc Clutches</b> (two drive)

## TOOLS

Part No.	Price Each	Description (Number Required)
4219	20.00	SMC Sprocket Wrench
4018	15.00	VORTEX Spring Wrench

VORTEX Spring Chart	Silver	Black	Gold
B&S FLAT HEAD - STOCK	X	X	
B&S OVH - ANIMAL	X	X	
HONDA / CLONE	X	X	
MODIFIED		X	X
OPENS			X

# ONE DISC CLUTCH for KART RACING ENGINES



**IMPORTANT - The Vortex RED clutch is designed to rotate in only one direction. The sprocket is attached to the drum with a left-hand thread and must be run inboard (sprocket adjacent to engine block) to prevent clutch damage.**

**Performance Notes** - The Vortex clutch was designed to engage very smoothly in order to avoid "bogging" the engine.

## Assembly -

1. Check the engine's crankshaft for smoothness and cleanliness. Remove all dirt, rust and burrs.
2. Install the short spacer with the chamfered edge of the spacer against the chamfer on the crankshaft.
3. If using a large sprocket, mount the sprocket followed by the long spacer. If using a small sprocket, mount the long spacer followed by the sprocket.
4. Install the clutch assembly and key followed by the end cap.
5. Install the hex head cap screw and torque to 460 inch pounds if threads are clean and dry, 270 inch pounds if the threads are coated with an anti-seize compound.

**Adjustment** - Set the engagement speed to the engine's peak torque RPM (typically 4000 RPM). The engagement speed is adjusted by removing the Vortex springs and repositioning the lower leg of each spring in another hole. The optional Vortex Spring Wrench, Part Number 4018 simplifies spring removal and replacement. The #2 position causes engagement at approximately 4000 RPM. The difference between adjacent holes is approximately 180 RPM.

**Maintenance** - Clutches like tires get dirty quickly. It is important to clean clutch discs every race weekend if not every heat if you want maximum acceleration.

Upon disassembly use an appropriate marker to identify the top sides of the drive plates and clutch disc if they will be reused. It is very important to replace each disc and drive plate in its original orientation. Heat and pressure force the drive plates into a permanently cupped shape and the soft disc will quickly wear into a conforming shape. These three pieces become a matched set. An upside down clutch disc or drive plate can cause poor contact between members and require another break-in process. Even if only one of these three parts is damaged, replace all three parts for maximum performance.

The Vortex clutch is not sensitive to air gap. Clutch disc thickness and taper do not affect performance. The criteria for replacing a disc are heat and chemistry i.e. replace the disc when it becomes glazed.

SMC highly recommends cleaning clutch (friction) discs mechanically NOT chemically. Brake cleaner and other chemicals are inadequate for removing dirt and other fine particles packed into the tiny voids. Do not use sandpaper on the 12 tab disc. A stainless steel utility brush (aka platers' brush) with a wire diameter of .006 is ideal for removing the hard-to-get-at dirt. The friction material is very porous and unfortunately works well as a dirt collector. Once the voids are filled and packed, the dirt starts to act as a lubricant (think tiny ball bearings) and causes the clutch to slip for a greater distance.

Drive plates that are tan, yellow, light blue or dark blue in very small areas and distorted less than 0.020 inch from flat may be reused. Heat and pressure cause friction material to separate from the clutch disc and bond to the drive plates. This friction material should be removed from the drive plates with sandpaper.

Use a Torx® T25 wrench and 60 inch pounds of torque to tighten the six button head cap screws.

Protect the clutch from moisture. Corrosion will diminish performance.

Additional information is available at the SMC web site [www.kartclutches.com](http://www.kartclutches.com)

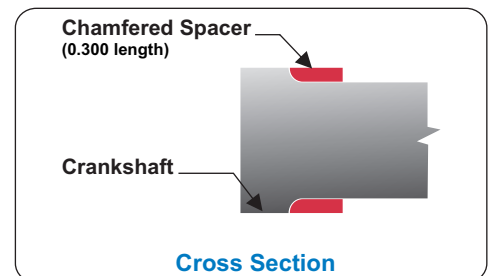
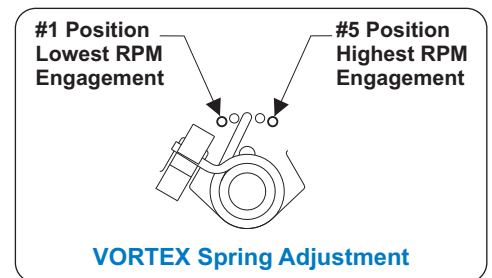

Structure Mechanics Corporation  
PO BOX 58148 • Cincinnati, OH • 45258  
513-598-1600 • [caf@kartclutches.com](mailto:caf@kartclutches.com)

[kartclutches.com](http://kartclutches.com)

# ONE DISC CLUTCH ASSEMBLY

## SPROCKET/DRUM ASSEMBLY

### Small Sprockets

11T - 14T - #35 Chain  
13T - 17T - #219 Chain

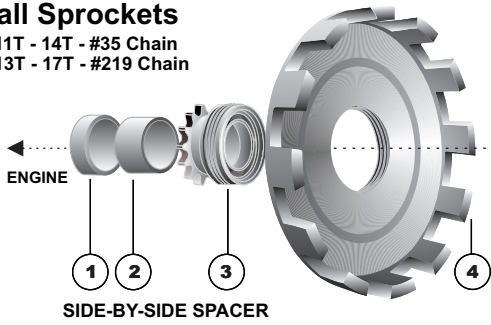

## CLUTCH ASSEMBLY

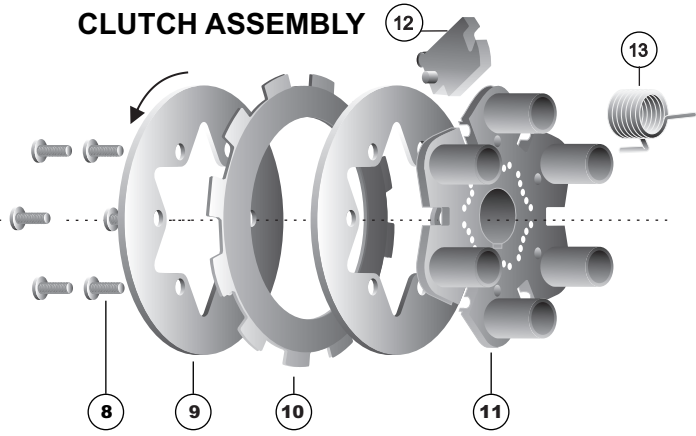

## SPROCKET/DRUM ASSEMBLY

### OutBoard - Right Hand

9T - 10T - #35 Chain  
11T - 12T - #219 Chain

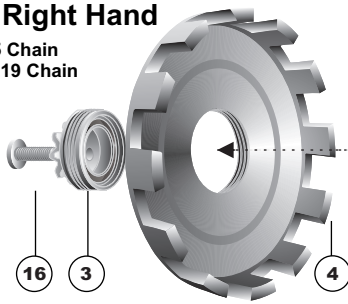

## CLUTCH ASSEMBLY

